



US008466613B2

(12) **United States Patent**
Yee

(10) **Patent No.:** **US 8,466,613 B2**
(45) **Date of Patent:** **Jun. 18, 2013**

(54) **ORGANIC LIGHT-EMITTING DISPLAY
DEVICE AND METHOD OF
MANUFACTURING THE SAME**

361/679.26, 679.55, 679.56, 806; 362/632-634;
445/25

See application file for complete search history.

(75) Inventor: **Dong-Su Yee, Yongin (KR)**

(56) **References Cited**

(73) Assignee: **Samsung Display Co., Ltd.,
Giheung-Gu, Yongin, Gyeonggi-Do (KR)**

U.S. PATENT DOCUMENTS

5,406,399 A * 4/1995 Koike 349/58
2011/0291553 A1 * 12/2011 Moon 313/504

(*) Notice: Subject to any disclaimer, the term of this
patent is extended or adjusted under 35
U.S.C. 154(b) by 325 days.

FOREIGN PATENT DOCUMENTS

JP 2002-040445 2/2002
KR 10-2007-0043385 4/2007
KR 10-2008-0001137 1/2008
KR 10-2009-0092240 8/2009

(21) Appl. No.: **13/017,149**

* cited by examiner

(22) Filed: **Jan. 31, 2011**

Primary Examiner — Nimeshkumar Patel

Assistant Examiner — Steven Horikoshi

(65) **Prior Publication Data**

US 2012/0056530 A1 Mar. 8, 2012

(74) *Attorney, Agent, or Firm* — Robert E. Bushnell, Esq.

(30) **Foreign Application Priority Data**

Sep. 2, 2010 (KR) 10-2010-0086171

(57) **ABSTRACT**

In an organic light-emitting display device which is thin and has excellent mechanical strength and a method of manufacturing the organic light-emitting display device, the organic light-emitting display device comprises: a panel including a first substrate and a second substrate coupled to each other by a sealing resin interposed between an internal surface of the first substrate and an internal surface of the second substrate, wherein a first concave portion is formed in an outer surface of the first substrate, and a second concave portion is formed in an outer surface of the second substrate; and a buffer cushion disposed in the first concave portion, wherein the density of an edge portion of the buffer cushion is greater than the density of a center portion of the buffer cushion.

(51) **Int. Cl.**

H01L 51/52 (2006.01)
H01L 51/56 (2006.01)
H05K 5/02 (2006.01)
H01J 9/40 (2006.01)

(52) **U.S. Cl.**

USPC **313/504**; 313/512; 361/679.21; 361/806;
445/25

(58) **Field of Classification Search**

USPC 313/504, 512; 349/58-60; 361/679.21,

18 Claims, 5 Drawing Sheets

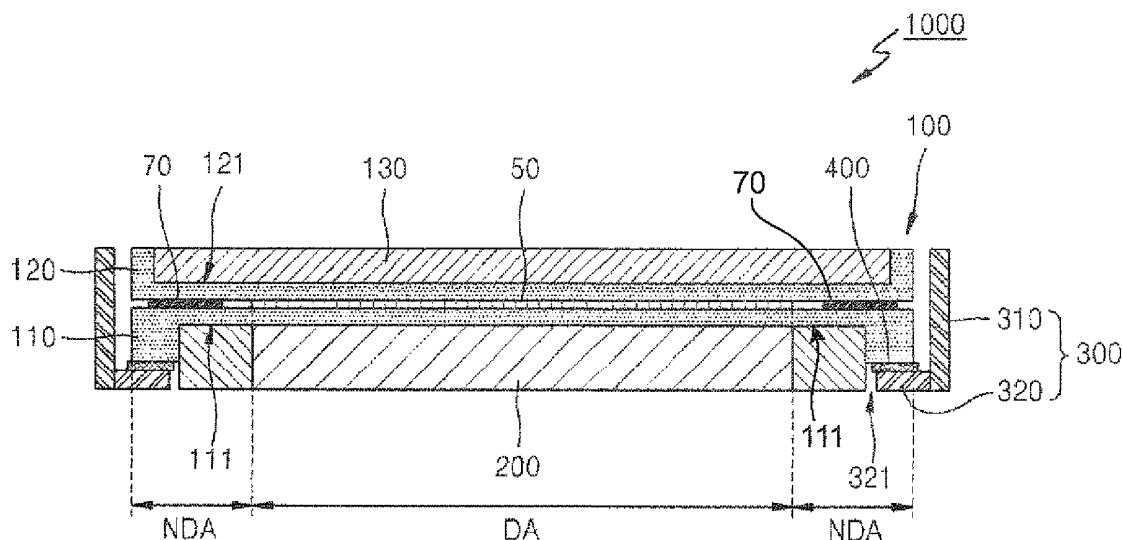
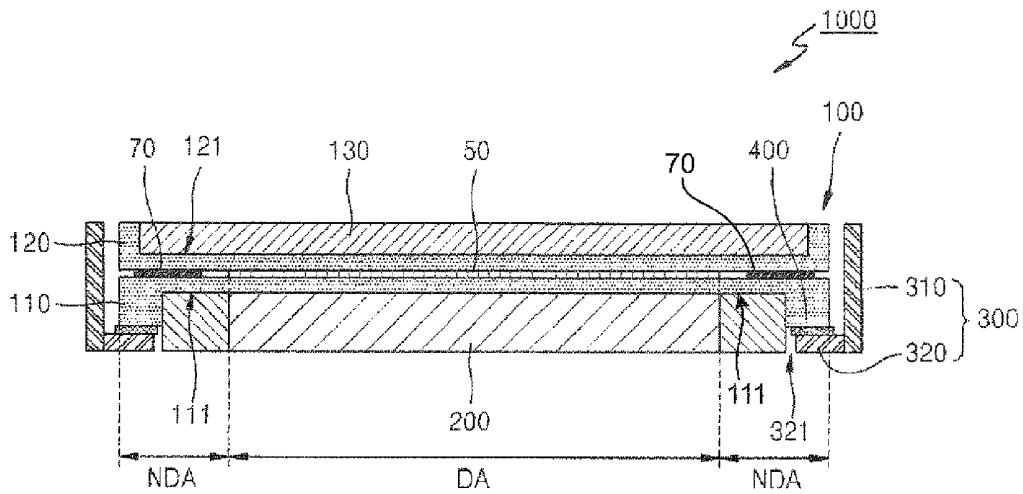

FIG. 1



which the sealing resin 70 is formed, the mechanical strength of the organic light-emitting display device 1000 may be improved. Meanwhile, the buffer cushion 200 having a low density is disposed at the region corresponding to the display area DA, and thus the impact absorption ability with respect to the display area DA may be increased.

In addition, since the adhesive material is applied to a surface of the buffer cushion 200 facing the first concave portion 111 of the first substrate 110, the buffer cushion 200 and the panel 100 may be firmly adhered to each other. The material, thickness, and various modified examples of the buffer cushion 200 have been described above in detail with reference to FIG. 1, and thus a repeated description thereof will be omitted.

The processes of FIGS. 6 and 7 may be simultaneously performed regardless of the order. The process of FIG. 7 may be performed before the process of FIG. 6. Alternatively, when the polarization member 130 is omitted, the process of FIG. 6 may be omitted when necessary.

Referring to FIG. 8, the adhesive member 400 is disposed between the lower plate 320 of the frame 300 and the panel 100, and the frame 300 accommodates the panel 100 and the buffer cushion 200. In particular, the frame 300 according to the current embodiment of the present invention includes the side wall 310 and the lower plate 320, and the cavity 321 is formed in the lower plate 320. The buffer cushion 200 is accommodated in the cavity 321 of the lower plate 320 so that the entire thickness of the organic light-emitting display device 1000 may be prevented from being decreased due to the thickness of the buffer cushion 200. In this regard, the side wall 310 of the frame 300 is spaced apart from the panel 100, and the side wall 310 surrounds the side walls of the frame 300 so as to protect the panel 100 against impacts and vibrations, thereby maintaining the uniform shape of the organic light-emitting display device 1000.

FIG. 9 illustrates the organic light-emitting display device 1000 including the buffer cushion 200, the polarization member 130, the panel 100 and the frame 300, which are coupled to one another. For example, if t is 1, the polarization member 130 may have a thickness of about 0.2 mm, the first substrate 110 and the second substrate 120 may have a thickness of 0.3 mm, and the lower plate 320 may have a thickness of about 0.1 mm. According to the current embodiment of the present invention, the first concave portion 111 and the second concave portion 121 have a depth of about 0.2 mm so as to offset the heights of the polarization member 130 and the buffer cushion 200. In addition, the cavity 321 is formed in the lower plate 320 of the frame 300 so as to further offset the height of the buffer cushion 200. Consequently, the entire thickness of the organic light-emitting display device 1000 is about 0.73 mm, and thus the slim organic light-emitting display device 1000 having a thickness of about 1 mm may be manufactured. However, the present invention is not limited thereto, and since t may be a positive real number, the thickness of each element is not limited to the case wherein t is 1. That is, if t is 0.7 or 0.5, the thickness of the organic light-emitting display device 1000 according to the current embodiment of the present invention may be further decreased.

In the present invention, the organic light-emitting display device 1000 is described as an example. However, the present invention is not limited thereto, and thus the present invention may be applied to various flat panel display devices, for example, a liquid crystal display (LCD), a plasma display panel (PDP), etc.

According to an organic light-emitting display device and a method of manufacturing the same of the present invention, concave portions are formed in an upper external surface and

a lower external surface of a panel, and a polarization member and a buffer cushion are disposed in the concave portions, and thus the slim organic light-emitting display device may be manufactured. In addition, a cavity is formed in a frame accommodating the panel, and a part of the panel is accommodated in the cavity, and thus the thickness of the organic light-emitting display device may be further decreased.

In addition, in the buffer cushion accommodated in the concave portion, the density of a portion corresponding to a non-display area of the panel is lower than that of a portion corresponding to the non-display area of the panel, and thus the mechanical strength of the non-display area may be improved.

While the present invention has been particularly shown and described with reference to exemplary embodiments thereof, it will be understood by those of ordinary skill in the art that various changes in form and detail may be made therein without departing from the spirit and scope of the present invention as defined by the following claims.

What is claimed is:

1. An organic light-emitting display device, comprising:
 - a panel including a first substrate and a second substrate coupled to each other by a sealing resin interposed between an internal surface of the first substrate and an internal surface of the second substrate, wherein a first concave portion is formed in an outer surface of the first substrate, and a second concave portion is formed in an outer surface of the second substrate; and
 - a buffer cushion disposed in the first concave portion, wherein a density of an edge portion of the buffer cushion is greater than a density of a center portion of the buffer cushion.
2. The organic light-emitting display device of claim 1, further comprising a frame including a side wall and a lower plate in which a cavity is formed and accommodating the panel and the buffer cushion, wherein the buffer cushion is accommodated in the cavity.
3. The organic light-emitting display device of claim 2, wherein the cavity is formed in a region corresponding to the first concave portion.
4. The organic light-emitting display device of claim 2, further comprising an adhesive member disposed between the lower plate and the panel.
5. The organic light-emitting display device of claim 2, wherein the side wall is spaced apart from the panel.
6. The organic light-emitting display device of claim 2, wherein the side wall surrounds side surfaces of the panel.
7. The organic light-emitting display device of claim 1, further comprising a polarization member disposed in the second concave portion.
8. The organic light-emitting display device of claim 1, wherein the first substrate is divided into a display area and a non-display area, an organic light-emitting device (OLED) is disposed in the display area, the sealing resin is disposed in the non-display area, and the first concave portion is formed in an outer surface of the first substrate corresponding to the display area and corresponding to a part of the non-display area close to the display area.
9. The organic light-emitting display device of claim 8, wherein the edge portion of the buffer cushion is disposed in a region corresponding to a part of the non-display area close to the display area, and the center portion of the buffer cushion is disposed in a region corresponding to the display area.
10. The organic light-emitting display device of claim 1, wherein the buffer cushion comprises urethane-based and acrylic-based materials, and an adhesive material is applied to a surface facing the first concave portion.

11

11. A method of manufacturing an organic light-emitting display device, the method comprising the steps of:
 providing a first substrate and a second substrate;
 manufacturing a panel by coupling the first substrate and the second substrate to each other by using a sealing resin between an internal surface of the first substrate and an internal surface of the second substrate, forming a first concave portion in an outer surface of the first substrate, and forming a second concave portion in an outer surface of the second substrate;
 disposing a buffer cushion in the first concave portion, wherein a density of an edge portion of the buffer cushion is greater than a density of a center portion of the buffer cushion; and
 accommodating the panel and the buffer cushion in a frame including a side wall and a lower plate in which a cavity is formed, wherein the buffer cushion is accommodated in the cavity.

12. The method of claim 11, wherein the step of manufacturing the panel further comprises disposing a polarization member in the second concave portion.

13. The method of claim 11, further comprising disposing an adhesive member between the lower plate and the panel before accommodating the panel and the buffer cushion in the frame.

12

14. The method of claim 11, wherein the first substrate is divided into a display area and a non-display area, an OLED is disposed in the display area, the sealing resin is disposed in the non-display area, and the first concave portion is formed in an outer surface of the first substrate corresponding to the display area and corresponding to a part of the non-display area close to the display area.

15. The method of claim 14, wherein the edge portion of the buffer cushion is disposed in a region corresponding to a part of the non-display area close to the display area, and the center portion of the buffer cushion is disposed in a region corresponding to the display area.

16. The method of claim 11, wherein the buffer cushion comprises urethane-based and acrylic-based materials, and an adhesive material is applied to a surface facing the first concave portion.

17. The method of claim 11, wherein the side wall is spaced apart from the panel.

18. The method of claim 11, wherein the side wall surrounds side surfaces of the panel.

* * * * *

FIG. 2

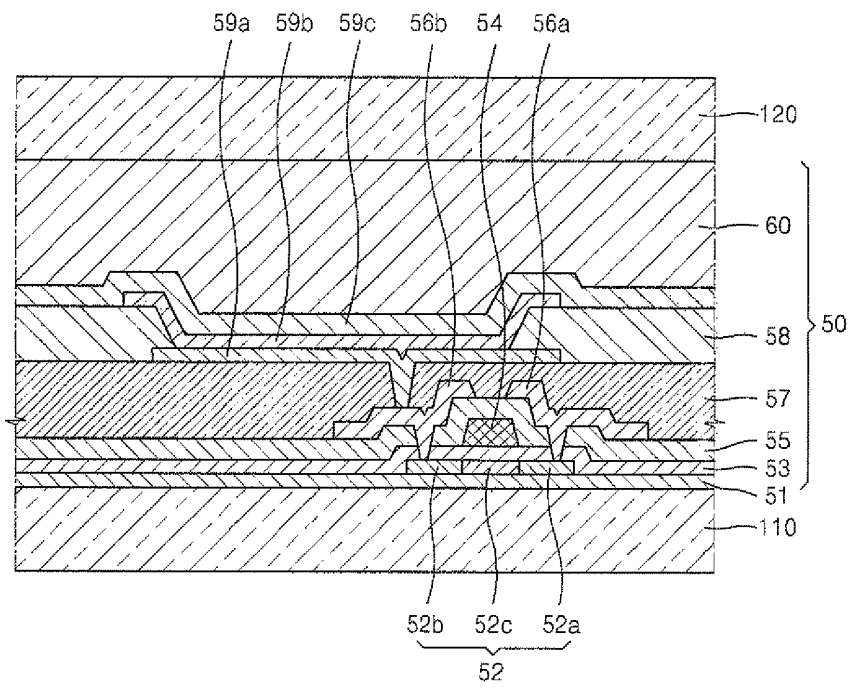

FIG. 3

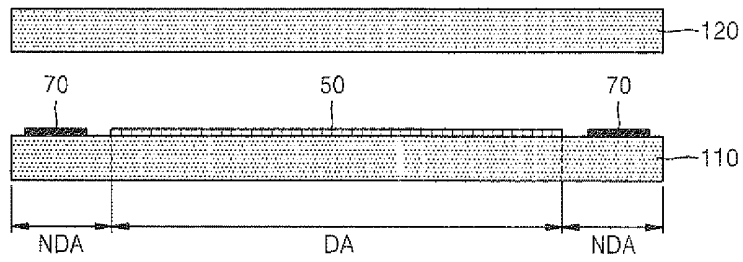

FIG. 4

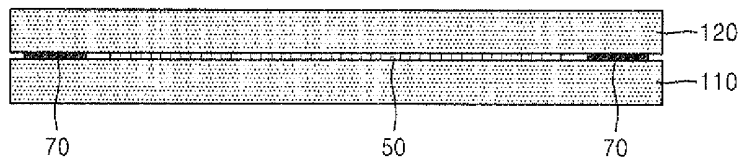

FIG. 5

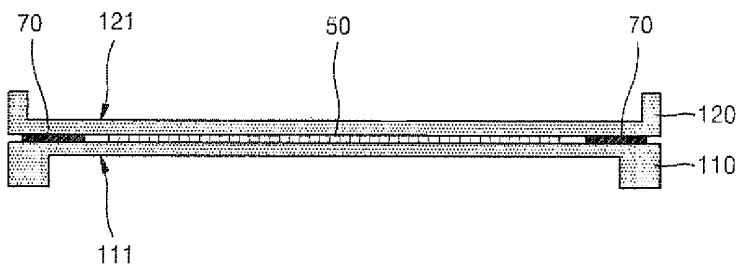

FIG. 6

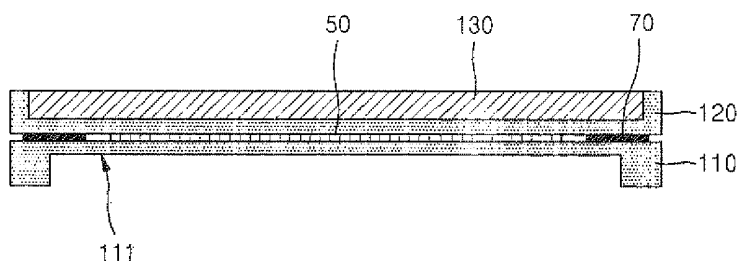

FIG. 7

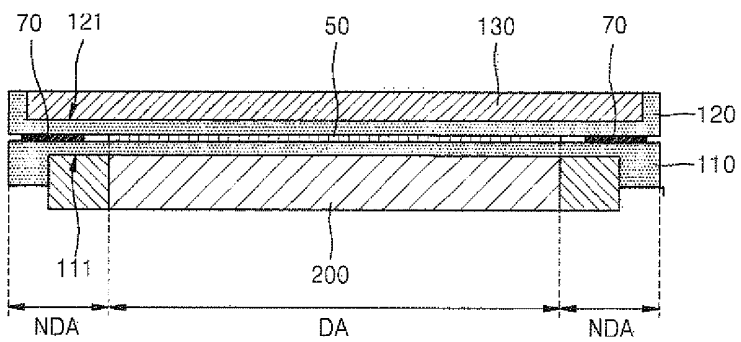

FIG. 8

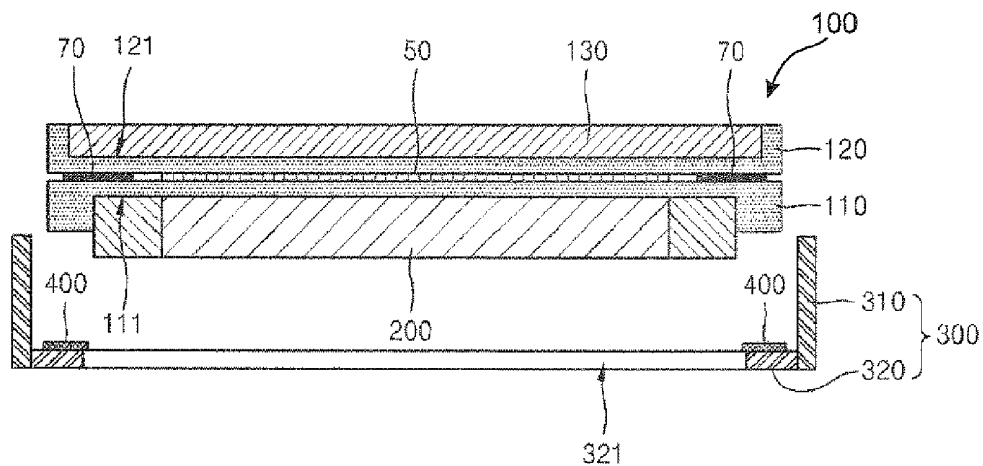
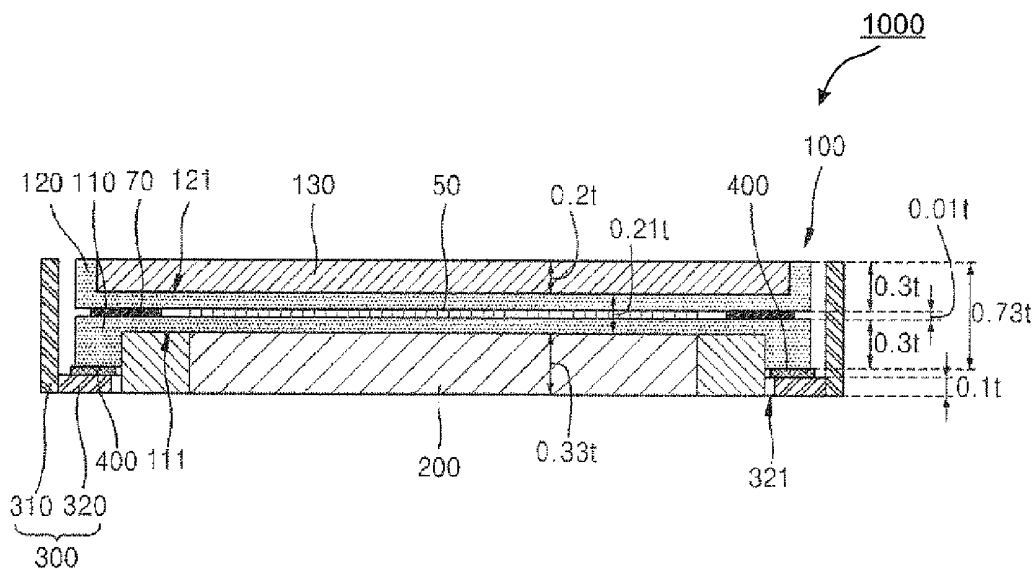

FIG. 9



**ORGANIC LIGHT-EMITTING DISPLAY
DEVICE AND METHOD OF
MANUFACTURING THE SAME**

CLAIM OF PRIORITY

This application makes reference to, incorporates the same herein, and claims all benefits accruing under 35 U.S.C. §119 from an application earlier filed in the Korean Intellectual Property Office on Sep. 2, 2010 and there duly assigned Serial No. 10-2010-0086171.

BACKGROUND OF THE INVENTION

1. Field of the Invention

The present invention relates to an organic light-emitting display device which is thin, and a method of manufacturing the same.

2. Description of the Related Art

Recently, the organic light-emitting display devices market is growing to include digital cameras, video cameras, personal digital assistants (PDAs), or displays for mobile devices such as mobile phones. Accordingly, organic light-emitting display devices are required to be thin, lightweight, and robust against breakage so as to be easily portable. Although a thin substrate is used to manufacture thin and lightweight organic light-emitting display devices, since a buffer member or a polarization member used in the assembly are included, the organic light-emitting display device cannot be made to have less than a predetermined thickness.

SUMMARY OF THE INVENTION

The present invention provides an organic light-emitting display device which is thin and has excellent mechanical strength, and a method of manufacturing the organic light-emitting display device.

According to an aspect of the present invention, there is provided an organic light-emitting display device comprising: a panel including a first substrate and a second substrate coupled to each other by using a sealing resin interposed between an internal surface of the first substrate and an internal surface of the second substrate, wherein a first concave portion is formed in an outer surface of the first substrate, and a second concave portion is formed in an outer surface of the second substrate; and a buffer cushion disposed in the first concave portion, wherein a density of an edge portion of the buffer cushion is greater than that of a center portion of the buffer cushion.

The organic light-emitting display device may further include a frame including a side wall and a lower plate in which a cavity is formed, and accommodating the panel and the buffer cushion, wherein the buffer cushion is accommodated in the cavity.

The organic light-emitting display device may further include a polarization member disposed in the second concave portion.

The first substrate is divided into a display area and a non-display area, an organic light-emitting device (OLED) is disposed in the display area, the sealing resin is disposed in the non-display area, and the first concave portion is formed in an outer surface of the first substrate corresponding to the display area, and corresponding to a part of the non-display area close to the display area.

The edge portion of the buffer cushion is disposed in a region corresponding to a part of the non-display area close to

the display area, and the center portion of the buffer cushion is disposed in a region corresponding to the display area.

The buffer cushion may include urethane-based and acrylic-based materials, and an adhesive material is applied to a surface facing the first concave portion.

The cavity is formed in a region corresponding to the first concave portion.

The organic light-emitting display device may further include an adhesive member disposed between the lower plate and the panel.

The side wall is spaced apart from the panel.

The side wall surrounds side surfaces of the panel.

According to another aspect of the present invention, there is provided a method of manufacturing an organic light-emitting display device, the method comprising: providing a first substrate and a second substrate; manufacturing a panel by coupling the first substrate and the second substrate to each other by using a sealing resin between an internal surface of the first substrate and an internal surface of the second substrate, forming a first concave portion in an outer surface of the first substrate, and forming a second concave portion in an outer surface of the second substrate; disposing a buffer cushion in the first concave portion, wherein a density of an edge portion of the buffer cushion is greater than that of a center portion of the buffer cushion; and accommodating the panel and the buffer cushion in a frame including a side wall and a lower plate in which a cavity is formed, wherein the buffer cushion is accommodated in the cavity.

The manufacturing of the panel may further include disposing a polarization member in the second concave portion.

The method may further include disposing an adhesive member between the lower plate and the panel before accommodating the panel and the buffer cushion in the frame.

The first substrate is divided into a display area and a non-display area, an OLED is disposed in the display area, the sealing resin is disposed in the non-display area, and the first concave portion is formed in an outer surface of the first substrate corresponding to the display area, and corresponding to a part of the non-display area close to the display area.

The edge portion of the buffer cushion is disposed in a region corresponding to a part of the non-display area close to the display area, and the center portion of the buffer cushion is disposed in a region corresponding to the display area.

The buffer cushion may include urethane-based and acrylic-based materials, and an adhesive material is applied to a surface facing the first concave portion.

The side wall is spaced apart from the panel.

The side wall surrounds side surfaces of the panel.

Another aspect, characteristics, and advantages of the present invention will become clearer from the following drawings, claims, and the detailed description of the present invention.

BRIEF DESCRIPTION OF THE DRAWINGS

A more complete appreciation of the invention, and many of the attendant advantages thereof, will be readily apparent as the same becomes better understood by reference to the following detailed description when considered in conjunction with the accompanying drawings, in which like reference symbols indicate the same or similar components, wherein:

FIG. 1 is a cross-sectional view illustrating an organic light-emitting display device according to an embodiment of the present invention;

FIG. 2 is a cross-sectional view illustrating a pixel included in a display area of FIG. 1; and

FIGS. 3 thru 9 are cross-sectional views for explaining a method of manufacturing the organic light-emitting display device of FIG. 1.

DETAILED DESCRIPTION OF THE INVENTION

Various changes in form and detail may be made therein, and thus the invention should not be construed as being limited to the embodiments set forth herein. As the inventive concept is not limited to the embodiments described in the present description, it should therefore be understood that the inventive concept does not include every kind of variation example or alternative equivalent included in the spirit and scope of the inventive concept. In the description, detailed descriptions of well-known functions and structures may be omitted so as not to hinder the understanding of the present invention.

In the present description, terms such as "first", "second", etc. are used to describe various elements. However, it is obvious that the elements should not be defined by these terms. The terms are used only for distinguishing one element from another element.

The terminology used herein is for the purpose of describing particular embodiments only and is not intended to be limiting of example embodiments. As used herein, the singular forms "a," "an" and "the" are intended to include the plural forms as well, unless the context clearly indicates otherwise. It will be further understood that the terms "comprises" and/or "comprising," when used in this specification, specify the presence of stated features, integers, steps, operations, elements, and/or components, but do not preclude the presence or addition of one or more other features, integers, steps, operations, elements, components, and/or groups thereof.

An exemplary embodiment according to the present invention will now be described in detail with reference to the accompanying drawings.

FIG. 1 is a cross-sectional view illustrating an organic light-emitting display device according to an embodiment of the present invention.

Referring to FIG. 1, the organic light-emitting display device **1000** includes a panel **100** in which a first substrate **110** and a second substrate **120** are coupled together by using a sealing resin **70**, a polarization member **130**, a buffer cushion **200**, an adhesive member **400**, and a frame **300**. Although not shown in FIG. 1, the organic light-emitting display device **1000** may further include a printed circuit board (PCB) (not shown) and a flexible circuit board (not shown) for connecting the panel **100** and the PCB.

The panel **100** includes the first substrate **110** and the second substrate **120**. The first substrate **110** and the second substrate **120** are coupled together by using the sealing resin **70** interposed between an internal surface of the first substrate **110** and an internal surface of the second substrate **120**, and disposed at edges of the first substrate **110**. The sealing resin **70** may be a sealant or a frit. The first substrate **110** and the second substrate **120** are coupled by hardening the sealing resin **70** by joule heat, a laser, or ultra violet (UV) light, and thus an organic light-emitting device (OLED) disposed between the first substrate **110** and the second substrate **120** may be sealed.

The first substrate **110** is divided into a display area DA and non-display areas NDA. The display area DA is a region for substantially displaying an image and includes a pixel **50**. Electronic devices, such as an OLED and a thin film transistor (TFT), are disposed in the pixel **50**. The non-display area NDA is a region not displaying an image and includes the

sealing resin **70**. The pixel **50** included in the display area DA will be described in detail below with reference to FIG. 2.

According to the current embodiment of the present invention, a first concave portion **111** is formed in an outer surface of the first substrate **110**, and a concave portion **121** is formed in an outer surface of the second substrate **120**. In this regard, the first concave portion **111** is formed in the outer surfaces of the first substrate **110** corresponding to the display area DA, and corresponding to a part of each of the non-display areas NDA close to the display area DA. The part of each of the non-display areas NDA may be the entire region in which the sealing resin **70** is disposed, or it may be a part of the region in which the sealing resin **70** is disposed. In other words, in the first substrate **110**, thicknesses of the display area DA and a part of the non-display area NDA may be less than a thickness of the remaining non-display area NDA. In the first substrate **110**, if a thickness of the non-display area NDA in which the first concave portion **111** is not formed is about $0.3t$ mm (where t is a positive real number), a thickness of the display area DA in which the first concave portion **111** is formed may be about $0.1t$ mm. In other words, the first concave portion **111** may be formed to a depth which is two-thirds the thickness of the first substrate **110**. If the thickness of the first concave portion **111** is greater than $0.2t$ mm, the first substrate **110** may be broken due to an impact, or if the thickness of the first concave portion **111** is less than $0.2t$ mm, when the buffer cushion **200** is placed in the first concave portion **111**, the thickness of the organic light-emitting display device **1000** may be increased. However, the present invention is not limited thereto, and the first concave portion **111** may be formed only in the outer surface of the first substrate **110** corresponding to the display area DA.

In addition, the second concave portion **121** is formed in outer surfaces of the second substrate **120** corresponding to the display area DA, and corresponding to a part of each of the non-display areas NDA close to the non-display area NDA. In other words, in the second substrate **120**, thicknesses of the display area DA and a part of the non-display area NDA may be less than the thickness of the remaining non-display area NDA. In the second substrate **120**, if a thickness of the non-display area NDA, in which the second concave portion **121** is not formed, is about $0.3t$ mm (where t is a positive real number), a thickness of the display area DA in which the second concave portion **121** is formed may be about $0.1t$ mm. In other words, the second concave portion **121** may be formed to a depth which is two-thirds the thickness of the second substrate **120**. If the thickness of the second concave portion **121** is greater than $0.2t$ mm, the second substrate **120** may be broken due to an impact, or if the thickness of the second concave portion **121** is less than $0.2t$ mm, when the polarization member **130** is placed in second concave portion **121**, the thickness of the organic light-emitting display device **1000** may be increased. However, the present invention is not limited thereto, and the second concave portion **121** may be formed only in the outer surface of the second substrate **120** corresponding to the display area DA.

Cross-sections of the first concave portion **111** and the second concave portion **121** may have a quadrilateral shape, one surface of which is opened, or they may have a shape having a curvature. The shapes of the first concave portion **111** and the second concave portion **121** may vary when necessary.

According to the current embodiment of the present invention, a concave portion is formed in each of the first concave portion **111** and the second concave portion **121** so as to reduce their weights, thereby reducing stress occurring in portions in which the sealing resins **70** are disposed. Accord-

ingly, cracks due to the stress occurring in the portions in which the sealing resins 70 are disposed may be remarkably reduced.

The buffer cushion 200 is disposed in the first concave portion 111. The buffer cushion 200 may include urethane-based and acrylic-based materials, and protects the panel 100 from an external impact. For example, the buffer cushion 200 may be formed of a sponge, which is made of urethane-based and acrylic-based materials, by foam-molding. In addition, the density of the buffer cushion 200 may be differently controlled according to a foam-molding condition and a ratio of a material to urethane-based material or acrylic-based material. In this regard, as the density of the buffer cushion 200 is increased, the buffer cushion 200 may rapidly absorb impact. On the other hand, as the density of the buffer cushion 200 is decreased, the buffer cushion 200 has a high impact absorption ability with respect to large impacts. Accordingly, the buffer cushion 200 having a low density is better for absorbing large impacts.

Meanwhile, an adhesive material may be applied to a surface of the buffer cushion 200 opposite to the first concave portion 111 so as to be adhered to the panel 100. The buffer cushion 200 may have a uniform thickness, and the thickness may be on average in the range of about $0.23t$ to about $0.33t$ mm (where t denotes a positive real number).

In the buffer cushion 200 according to the current embodiment of the present invention, the density of an edge portion is greater than that of a center portion. In this regard, the edge portion of the buffer cushion 200 may be disposed so as to correspond to a part of the non-display area NDA close to the display area DA, and the center portion may be disposed so as to correspond to the display area DA. A density of the buffer cushion 200 may vary with a concentration gradient, or it may vary with a boundary at which the density of the buffer cushion 200 is clearly distinguished. The point is that the buffer cushion 200 having a higher density is disposed at a region in which the sealing resin 70 is formed. Thus, since the buffer cushion 200 having a higher density may effectively and rapidly absorb an impact occurring in the region in which the sealing resin 70 is formed, mechanical strength of the organic light-emitting display device 1000 may be improved. Meanwhile, the buffer cushion 200 having a low density is disposed at the region corresponding to the display area DA, and thus impact absorption ability with respect to the display area DA may be increased.

The polarization member 130 may be disposed in the second concave portion 121 so as to suppress external light reflection of the panel 100. The polarization member 130 is disposed so as to improve an optical characteristic of the panel 100, but may be omitted when necessary. The polarization member 130 has a uniform thickness, and the thickness may be on average in the range of about $0.15t$ to about $0.2t$ mm (where t denotes a positive real number).

Hereinafter, the thickness of the panel 100 including the buffer cushion 200 and the polarization member 130 will be described. For example, when t is 1, the thickness of the buffer cushion 200 may be about 0.33 mm, the thickness of the polarization member 130 may be about 0.2 mm, and the thicknesses of the first substrate 110 and the second substrate 120 may be about 0.3 mm. However, the first concave portion 111 and the second concave portion 121 having a depth of about 0.2 mm are formed in the first substrate 110 and the second substrate 120, respectively, and the buffer cushion 200 and the polarization member 130 are disposed in the first concave portion 111 and the second concave portion 121, respectively. Thus, a thin panel assembly may be manufactured.

The frame 300 accommodates the panel 100 and the buffer cushion 200. The frame 300 includes a side wall 310 and a lower plate 320. A large cavity 321 is formed in the lower plate 320. The cavity 321 is formed so as to correspond to the first concave portion 111 and accommodates the buffer cushion 200. In other words, the buffer cushion 200 is exposed to the outside through the cavity 321. The side wall 310 and the lower plate 320 may have a thickness of about 0.1t mm (where t denotes a positive real number). The side wall 310 and the lower plate 320 may be formed as one body, and may be adhered to each other when necessary.

Thus, the buffer cushion 200, which is thicker than the first concave portion 111, may be accommodated in the cavity 321 of the frame 300 so that the thickness of the organic light-emitting display device 1000 may be prevented from being increased, and thus the slim organic light-emitting display device 1000 may be manufactured.

When the frame 300 accommodates the panel 100, the frame 300 may further include an adhesive member 400 included between the lower plate 320 and the panel 100 in order to fix the panel 100. The adhesive member 400 may be an adhesive tape or any of various adhesives. The side wall 310 is spaced apart from the panel 100, and is formed so as to surround side surfaces of the panel 100.

FIG. 2 is a cross-sectional view illustrating the pixel included in the display area of FIG. 1.

Referring to FIG. 2, an insulating layer 51 (for example, a barrier layer and/or a buffer layer) may be formed on the first substrate 110 so as to prevent impurity ions from spreading, and so as to prevent water or external air from entering, as well as to planarize a surface of the first substrate 110.

An active layer 52, which is a TFT formed of a semiconductor material, may be formed on the insulating layer 51, and a gate insulating layer 53 is formed so as to cover the active layer 52. The active layer 52 may be formed of an inorganic semiconductor, such as amorphous silicon or poly silicon, or an organic semiconductor. The active layer 52 may include a source region 52a, a drain region 52b, and a channel region 52c disposed between the source region 52a and the drain region 52b.

A gate electrode 54 is formed on the gate insulating layer 53, and an insulating interlayer 55 is formed so as to cover the gate electrode 54. A source electrode 56a and a drain electrode 56b are formed on the insulating interlayer 55, and a planarization layer 57 and a pixel-defining layer 58 are sequentially formed so as to cover the source electrode 56a and the drain electrode 56b.

The gate insulating layer 53, the insulating interlayer 55, the planarization layer 57, and the pixel-defining layer 58 may be formed of an insulating material so as to have a single layer structure or a multi-layered structure, and may be formed of an organic material, an inorganic material, or an organic/inorganic composite material. However, the stacked structure of the TFT is not limited thereto, and may have any of various structures.

Meanwhile, a pixel electrode 59a, which is an electrode of an OLED, may be formed on the planarization layer 57, and a pixel-defining layer 58 may be formed on the pixel electrode 59a. A predetermined opening is formed in the pixel-defining layer 58 so as to expose the pixel electrode 59a, and an organic light-emitting layer 59b of the OLED is then formed on the pixel electrode 59a.

The OLED emits red, green and blue light according to the flow of current. The OLED includes the pixel electrode 59a contacting the drain electrode 56b of the TFT through a contact hole, a counter electrode 59c covering the entire pixel,

and the organic light-emitting layer **59b** which is disposed between the pixel electrode **59a** and the counter electrode **59c**, and which emits light.

The pixel electrode **59a** and the counter electrode **59c** are insulated from each other by the organic light-emitting layer **59b**. Voltages having different polarities are applied to the organic light-emitting layer **59b** so that the organic light-emitting layer **59b** emits light.

The organic light-emitting layer **59b** may be a low-molecular weight organic layer or a polymer organic layer. The organic light-emitting layer **59b** may include a hole injection layer (HIL), a hole transport layer (HTL), an emission layer (EML), an electron transport layer (ETL), and an electron injection layer (EIL) which are stacked in a single layer structure or a multi-layered structure. An organic material used to form the organic light-emitting layer **59b** may be copper phthalocyanine (CuPc), N,N'-Di(naphthalene-1-yl)-N,N'-diphenyl-benzidine (NPB), tris-8-hydroxyquinoline aluminum (Alq3), or the like. The organic layer may be formed by using a vacuum evaporation method. The HIL, the HTL, the ETL and the EIL, which are common layers, may be commonly used in red, green and blue pixels. Accordingly, unlike FIG. 2, the common layers may be formed so as to cover the entire pixel similar to the counter electrode **59c**.

The pixel electrode **59a** may function as an anode, and the counter electrode **59c** may function as a cathode. Alternatively, the polarities of the pixel electrode **59a** and the counter electrode **59c** may be reversed.

In a bottom emission type display, in which an image is displayed toward the first substrate **110**, the pixel electrode **59a** may be a transparent electrode, and the counter electrode **59c** may be a reflection electrode. At this point, the pixel electrode **59a** may be formed of a high-work function material, for example, ITO, IZO, ZnO, In₂O₃, etc., and the counter electrode **59c** may be formed of a low-work function metal, for example, Ag, Mg, Al, Pt, Pd, Au, Ni, Nd, Ir, Cr, Li, Ca, etc.

In a top emission type display, in which an image is displayed toward the counter electrode **59c**, the pixel electrode **59a** may be a reflection electrode, and the pixel electrode **59a** may be a transparent electrode. The reflection electrode, which is the pixel electrode **59a**, may include a reflection layer which is formed of any one selected from the group consisting of Ag, Mg, Al, Pt, Pd, Au, Ni, Nd, Ir, Cr, Li, and Ca, or a combination thereof, and a high-work function material, for example, ITO, IZO, ZnO, In₂O₃, etc. The transparent electrode, which is the counter electrode **59c**, may be formed by depositing a low-work function metal which is any one selected from the group consisting of Ag, Mg, Al, Pt, Pd, Au, Ni, Nd, Ir, Cr, Li, and Ca, or a combination thereof, and then forming an auxiliary electrode layer or a bus electrode line formed of a transparent conductive material, for example, ITO, IZO, ZnO, or In₂O₃, thereon.

In a both-sides emission type display, both the pixel electrode **59a** and the counter electrode **59c** may be a transparent electrode. However, as illustrated in FIG. 1, when the first substrate **110** is seated in the frame **300**, the organic light-emitting display device **1000** may be a top emission type display in which an image is displayed toward the second substrate **120**.

The pixel electrode **59a** and the counter electrode **59c** may not be formed of the above-described materials, and may be formed of a conductive organic material or a conductive paste including conductive particles, such as Ag, Mg, Cu, or the like. When the conductive paste is used to form the pixel electrode **59a** and the counter electrode **59c**, the pixel electrode **59a** and the counter electrode **59c** may be printed by using an inkjet printing method, and then may be calcined.

A passivation layer **60**, which is formed of an organic material, an inorganic material, or an organic/inorganic composite material, may further be formed on the counter electrode **59c** so as to cover the OLED. The second substrate **12** may be formed on the passivation layer **60**.

FIGS. 3 thru 9 are cross-sectional views for explaining a method of manufacturing the organic light-emitting display device of FIG. 1.

Referring to FIG. 3, the first substrate **110** and the second substrate **120** are provided. The first substrate **110** and the second substrate **120** may be a transparent glass or a plastic substrate formed of polyimide (PI). The pixel **50**, including an electronic device such as an OLED or a TFT, may be disposed in the display area DA of the first substrate **110**. The sealing resin **70**, such as a sealant or a frit, may be disposed in the non-display area NDA of the first substrate **110**.

Referring to FIG. 4, the first substrate **110** and the second substrate **120** may be coupled by using the sealing resin **70**. In detail, an internal surface of the first substrate **110** and an internal surface of the second substrate **120** are coupled so as to face each other, and the sealing resin **70** is hardened by applying light or heat in a region at which the sealing resin **70** is disposed, thereby sealing the first substrate **110** and the second substrate **120**.

Referring to FIG. 5, the first concave portion **111** is formed in an outer surface of the first substrate **110**, and the second concave portion **121** is formed in an outer surface of the second substrate **120**. The first concave portion **111** and the second concave portion **121** may be formed by wet etching or dry etching. In this regard, the outer surface is a surface opposite to an internal surface of a substrate to which the electronic device is adhered. The first concave portion **111** may be formed in the display area DA and in a part of each of the non-display areas NDA. In detail, the first concave portion **111** is formed in the display area DA and even in the non-display area NDA close to the display area DA. The second concave portion **121** may also be formed in the display area DA and in a part of each of the non-display areas NDA. The second concave portion **121** may be formed so as to have a size corresponding to that of the first concave portion **111**. However, the present invention is not limited thereto, and thus the second concave portion **121** may be formed over a wider region. The shapes, depths, and arrangements of the first concave portion **111** and the second concave portion **121** have been described above in detail with reference to FIG. 1, and thus a repeated description thereof will be omitted.

Referring to FIG. 6, the polarization member **130** is disposed in the second concave portion **121**. The polarization member **130** is disposed so as to improve an optical characteristic of the organic light-emitting display device **1000**. An adhesive material is applied to a surface of the polarization member **130** facing the second concave portion **121**, and thus the polarization member **130** and the second substrate **120** may be coupled to each other by the adhesive material.

Referring to FIG. 7, the buffer cushion **200** is disposed in the first concave portion **111**. In the buffer cushion **200**, the density of an edge portion is greater than that of a center portion. In this regard, the edge portion of the buffer cushion **200** may be disposed so as to the non-display area NDA, and correspond to the center portion may be disposed so as to correspond to the display area DA. In detail, referring to FIG. 7, the buffer cushion **200** may be disposed so as to correspond to a part of the non-display area NDA which is close to the display area DA. In this regard, the non-display area NDA is a region in which the sealing resin **70** is disposed. Thus, since the buffer cushion **200** having a higher density may effectively and rapidly absorb an impact occurring in the region in

专利名称(译)	有机发光显示装置及其制造方法		
公开(公告)号	US8466613	公开(公告)日	2013-06-18
申请号	US13/017149	申请日	2011-01-31
[标]申请(专利权)人(译)	三星显示有限公司		
申请(专利权)人(译)	三星移动显示器有限公司.		
当前申请(专利权)人(译)	三星DISPLAY CO., LTD.		
[标]发明人	YEE DONG SU		
发明人	YEE, DONG-SU		
IPC分类号	H01L51/52 H01J9/40 H01L51/56 H05K5/02		
CPC分类号	H01L51/52 H01L51/5237 H01L51/524 H01L51/5281		
审查员(译)	帕特尔NIMESHKUMAR		
优先权	1020100086171 2010-09-02 KR		
其他公开文献	US20120056530A1		
外部链接	Espacenet USPTO		

摘要(译)

在薄且具有优异机械强度的有机发光显示装置和制造有机发光显示装置的方法中，有机发光显示装置包括：面板，包括第一基板和连接到第二基板的第二基板。通过介于第一基板的内表面和第二基板的内表面之间的密封树脂彼此相对，其中第一凹部形成在第一基板的外表面中，第二凹部形成在外部第二基板的表面；缓冲垫设置在第一凹部中，其中缓冲垫的边缘部分的密度大于缓冲垫的中心部分的密度。

